

Scala 3:1

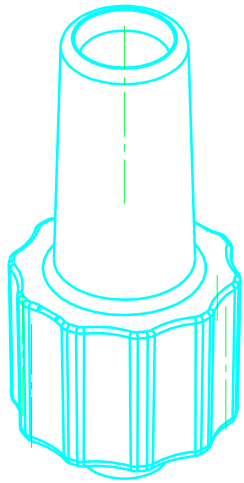
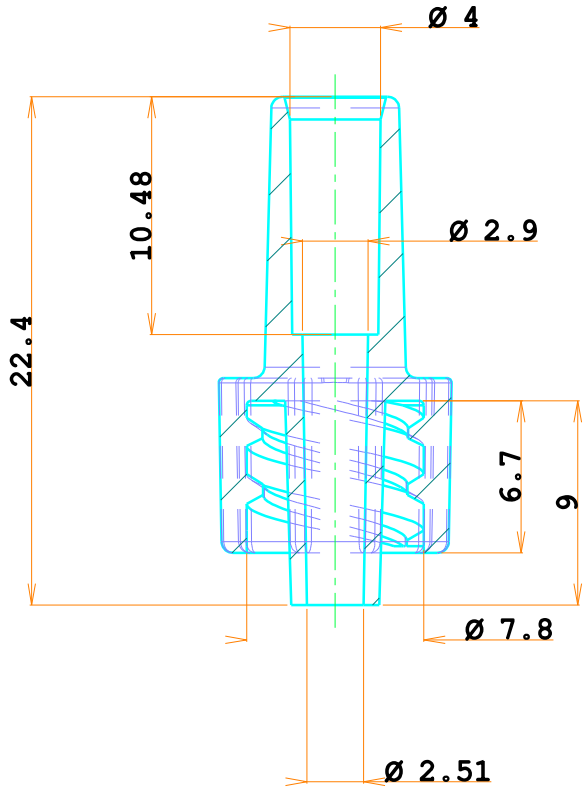
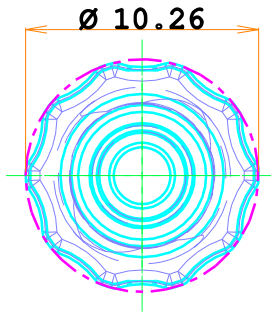
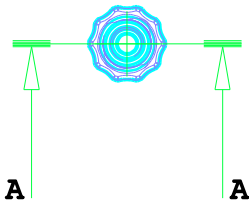
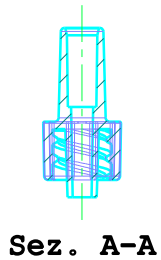

3 2 1

Changes

Signature

Date

 **CARRO LUIGI Srl**  
 25030 RUDIANO (BS)  
 Via Lavoro & Industria

**M0803.04 rev.00**

General Tolerances	ISO 2768-mk
0.5 < x < 6	+0.1
6 < x < 30	+0.2
30 < x < 120	+0.3
120 < x < 400	+0.5

Mould Denomination

N° Cavities

Order

Member Denomination

Customer code

**LUER FOR INTERNAL TUBE**

Date  
12/01/2023

Molding Material  
PC

C.tion

Machine

Mould Weight

Customer part

Drawn By  
Cassani M.

Approved By  
Direzione C.A.

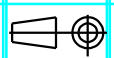

Eyebolts

Mould Dimensions

**ST 2421**

N°Par.

N°Pez.

Dimensions

Material

Treatment

Scale

**A4**

**Sheet**  
1/1