

Sez. A-A

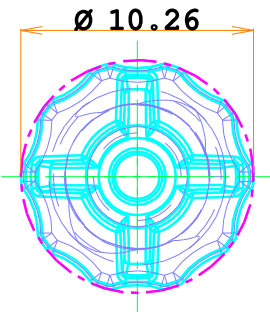

Ø 10.26

Scala 3:1

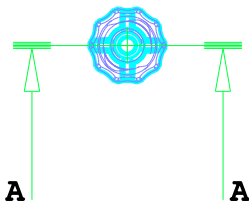
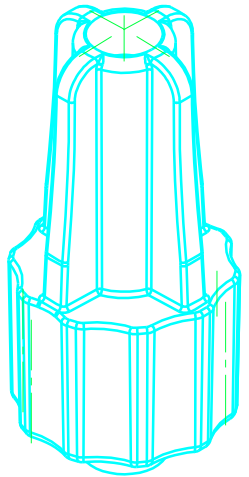

Scala 3:1

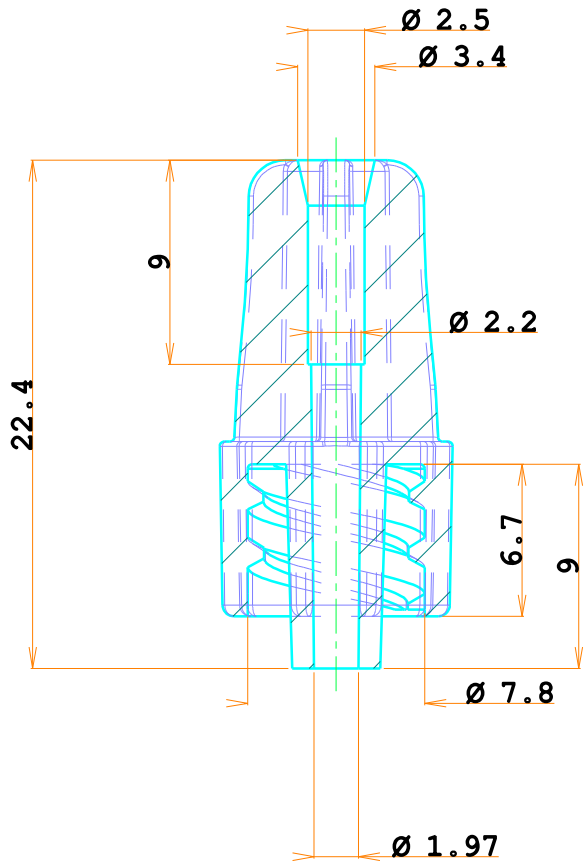

CARRO LUIGI Srl
 25030 RUDIANO (BS)
 Via Lavoro & Industria

M0803.04 rev.00

| General Tolerances | | ISO 2768-mk |
|--------------------|-----------|-------------|
| 0.5 | < x < 6 | +0.1 |
| 6 | < x < 30 | +0.2 |
| 30 | < x < 120 | +0.3 |
| 120 | < x < 400 | +0.5 |

Mould Denomination

N° Cavities

Order

Member Denomination

Customer code

MALE LUER FOR INTERNAL TUBE

Date
12/01/2023

Molding Material
PC

C.tion

Machine

Mould Weight

Customer part

Drawn By
Cassani M.

Approved By
Direzione C.A.

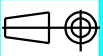

Eyebolts

Mould Dimensions

2285

N°Par.

N°Pez.

Dimensions

Material

Treatment

Scale

A4

Sheet 1/1

| | | |
|---|---|---|
| 3 | 2 | 1 |
| | | |
| | | |

Changes

Signature

Date