

LUER CONE ISO 80369-7

MATERIAL	COLOR	CODE	GAUGE	Ø A	B
ABS	LIGHT GREEN	TAPFI2,75_S	//	Ø 2.75	7.0
ABS	LIGHT BLUE	TAPFI2,10_S	//	Ø 2.10	7.0
ABS	BLUE	TAPFI1,65_S	//	Ø 1.65	4.0
ABS	WHITE	TAPFI1,30_S	//	Ø 1.30	3.0
ABS	RED	TAPFI1,25_S	//	Ø 1.25	2.0
ABS	PINK	TAPFI1,00_S	//	Ø 1.00	2.0
ABS	BEIGE	TAPFI0,9_S	//	Ø 0.90	2.0
PC	TRANSPARENT	TAPFI1	//	Ø 1.00	3.5
ABS	LIGHT GREEN	TAPFI2,8	//	Ø 2.8	3.5
ABS	LIGHT BLUE	TAPFI2,1A	//	Ø 2.00	3.5
ABS	BLUE	TAPFI1,7B	//	Ø 1.65	4.5
ABS	RED	TAPFI1,3R	//	Ø 1.30	2.5
ABS	BEIGE	TAPFI0,9B	//	Ø 0.90	2.0
PC	YELLOW	TAPFI20C	20G coax	Ø 0.90	2.0
PC	TRANSPARENT	TAPFI20CT	20G coax	Ø 0.90	2.0
PC	PINK	TAPFI18C	18G coax	Ø 1.30	3.5
PC	WHITE	TAPFI18CS	18G coax	Ø 1.30	3.5
PC	TRANSPARENT	TAPFI18CT	18G coax	Ø 1.30	3.5
PC	LIGHT BLUE	TAPFI14CS	14G coax Special	Ø 2.10	3

26/10/2023	M. BELOTTI	2	NEW VERSION ADDED
	A.LANZA	1	NEW VERSION ADDED
13/03/2023			Modifica
			Firma
			Date

Scale 4:1

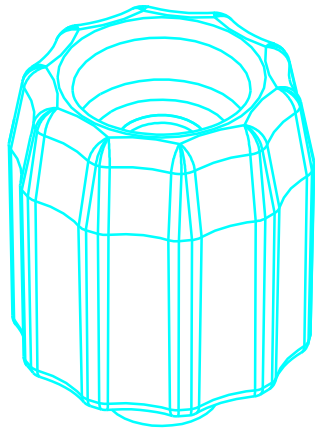

CARRO LUIGI Srl
 25030 RUDIANO (BS)
 Via Lavoro & Industria

M0803.04

Tolerance General	ISO 2768-mk
0.5 <x < 6	+0.1
6 <x < 30	+0.2
30 <x < 120	+0.3
120 <x < 400	+0.5

Mould Denomination
 OUR ST ST2284 / MOULDING COD ST100

N° Cavities

Order

Member Denomination
 CAP WITH THREAD

Customer code

TAPFIXXX

Date: 26/10/2023
 Molding Material: SEE TABLE
 C.tion: _____ Machine: _____ Mould Weight: _____

Customer part
 SEE TABLE

Drawn By: M. Belotti
 Approved By: Direzione C.A.
 N° Par.: _____ N° Pez.: _____ Dimensions: _____ Material: _____ Treatment: _____ Scale: 4:1

Sheet 1/1

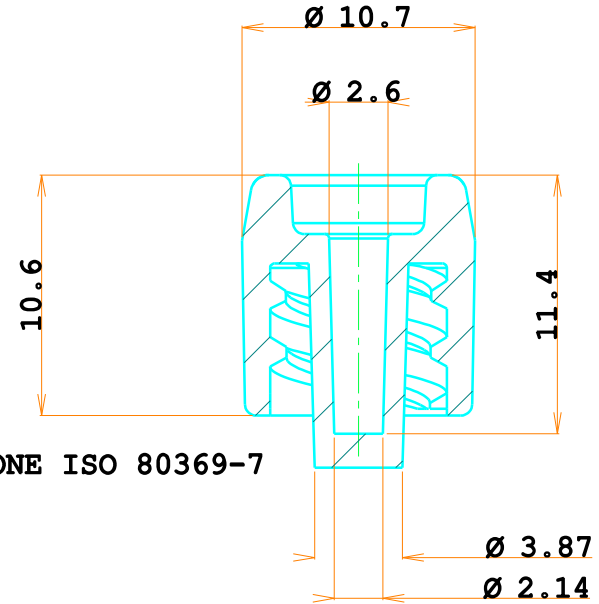
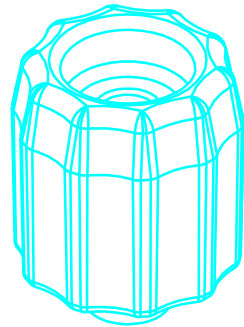

LUER CONE ISO 80369-7

Scala 3:1



Sez. A-A

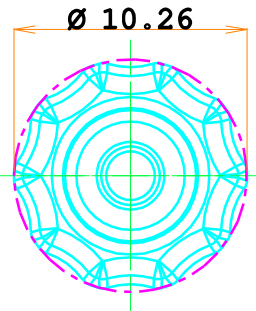

Scala 3:1

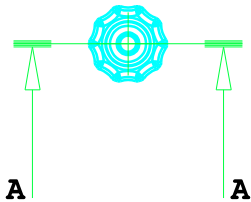



3 2 1

Changes

Signature

Date

 CARRO LUIGI Srl 25030 RUDIANO (BS) Via Lavoro & Industria	<u>Mould Denomination</u>			<u>N°Cavities</u>	<u>Order</u>
	-----			---	---
M0803.04 rev.00 <u>General Tolerances</u> ISO 2768-mk 0.5 < x < 6 +0.1 6 < x < 30 +0.2 30 < x < 120 +0.3 120 < x < 400 +0.5	<u>Member Denomination</u>			<u>Customer code</u>	
	BLIND CAP WITH THREAD			---	
<u>Date</u> 16/01/2023 <u>Drawn By</u> Cassani M. <u>N°Par.</u> <u>N°Pez.</u>	<u>Molding Material</u> PC COVERING GREEN <u>Approved By</u> Direzione C.A. <u>Dimensions</u>	<u>C.tion</u> 	<u>Machine</u> <u>Eyebolts</u>	<u>Mould Weight</u> -----	
				<u>Customer part</u> TAPFI	
<u>Material</u> -----		<u>Treatment</u> -----	<u>Scale</u> 3:1	<u>Mould Dimensions</u> -----	
				<u>Sheet</u> 1/1	